

# MX DYNAMIC



## Main features

- Cadences up to 100 ppm.
- Capacity: 3 kg - 1 g / 6 kg - 2 g with motorized belts width 230 mm.
- Capacity: 6 kg - 2 g with motorized belts width 230, 275 and 320 mm.
- From 3 to 4 motorized belts, closed loop.
- Brushless motors and drive boards, speed up to 70 m/min.
- Working temperature: from 0 °C to + 40 °C.
- Power supply: 230 Vac (Hz 50/60).
- Maximum supply: 3 belts 1,15 kW, 4 belts 1,15 kW.
- Resistive PC/Panel 12" display, suitable for use with gloves and in the presence of water/condensation.
- Structure and carpentry in aluminum and stainless steel.
- Belt height from the ground: 850 +/- 50 mm.
- Machine management by PLC.
- Print mode: thermal transfer and/or direct.
- Resolution: 8 dots/mm, 203 dpi (optional: 12 dots/mm, 300 dpi).
- Print speed: 203 dpi, 457 mm/s - 300 dpi, 300 mm/s.
- Label dimensions: from 40x40 to 100 mm x 110 mm.
- Print width: 104 mm.
- Internal diameter of the roll: 76 mm.
- Outer diameter of the roll: 300 mm.
- 600 meter ribbon capacity.
- Label application with compressed air (AIR BLAST), 6 bar 60 l/min, multi-label chamber with mechanical adjustment and position indicator.
- Label application by pneumatic rotary arm with sponge application plate, consumption 4/6 bar 40 l/min.
- Mechanical handling printing unit horizontal, vertical and rotational (180°).

## Software

- Weight pricing program.
- Sw custom label editor program.

### Selectable functions

- Variable weight processing and/or fixed weight.
- External availability for data sharing.
- Weighing range selection, change PLU and label format in progress (enable label format based on weight).
- Selection of PLU by reading barcode.
- Viewing reports on checks performed.
- Export production report on USB port.
- Multilingual selection.
- Multi-level password.

### PLU

- PLU number: 9999.
- For each PLU:
  - 5 free and variable text fields, respectively 700, 600 and 3 of 500 characters.
  - 75 variable fields, description, ingredients, expiration, seasoning, price, lot, customer, traceability.
  - All fields can be printed in bold, italic, underlined, single character, supporting different types (font, alignments, dimensions, bold etc.) of character in the same text.
- Automatic programming of machine parameters (motor speed, minimum and maximum weighing threshold, duration and delay expulsion, label and variable application along the X axis).
- Support of all barcodes.
- Through database is possible to combine archive Customers to archive Traceability.

**Traceability**

---

- Maximum number of lots: 9999.
- For each lot:
  - 10 lines of 50 characters of each for the data sent by the back office.
  - Or manual data entry (scanner for EAN128 ?).
  - Weight limit with configurable alarm.
  - Expiration data with configurable notice.

**Label formats**

---

- Customizable label formats: 1000 (print format editable on the machine).
- Rotation of the label format: 0, 90, 180, 270.
- Rotation of fields.

**Nutritional data**

---

- Print the nutritional data in table format.
- Print data for standard sizes (100 g) and/or per serving.
- Print RDA.

**Automatic and manual totals**

---

**Manuels:**

- Subtotal.
- Totals per PLU.
- Totals per lot of traceability, lot/PLU.
- Elimination of all partial processing.

**Automatic:**

---

- Total box.
- Total pallet.
- Total production.
- Elimination of the last two accumulated boxes.

**I/O Section**

---

- 1 USB 2.0.
- 1 Ethernet.
- 2 Electrical signals (clean contacts).

**Diagnostics**

---

- Continuous monitoring of the status of the machine and of all integrated systems (consent from downstream, motor failure, encumbrances on the belts and all errors resulting from the printing system such as paper end, end ribbon, paper passage and wear of the print head).



## Options

- 6000 divisions.
- Capacity: 15 kg - 5 g.
- Network machine management software with RS Server communication protocol.
- Print resolution: 300 dpi, speed 300 mm/s.
- Bench labeling machine for totalisations.
- 2D camera for presence of the label.
- 2D camera for reading QR Code.
- External PROFIBUS interface, Profibus protocol with PCB.
- Communication protocol ETHERCAT.
- Piston ejector, arm or pneumatic blow.
- Collection basket in stainless steel or plastic.
- Waste roller conveyor with collection basket.
- Overflow photocell.
- Led light column for out of tolerance and alarms.

## Dimensions

### **Series 230 useful belt dimensions [mm]**

SYNCHRONIZER	CADENCE	WEIGHING	LABELING
-	230x510	230x510	230x1600
230x510	230x510	230x510	230x1600

### **Series 275 useful belt dimensions [mm]**

SYNCHRONIZER	CADENCE	WEIGHING	LABELING
-	275x510	275x510	275x1600
275x510	275x510	275x510	275x1600

### **Series 320 useful belt dimensions [mm]**

SYNCHRONIZER	CADENCE	WEIGHING	LABELING
-	320x510	320x510	320x1600
320x510	320x510	320x510	320x1600

**Note: for output belts, labelers, ejectors, vision systems, diverters and banding machines refer to the technical data sheets.**

# Layout

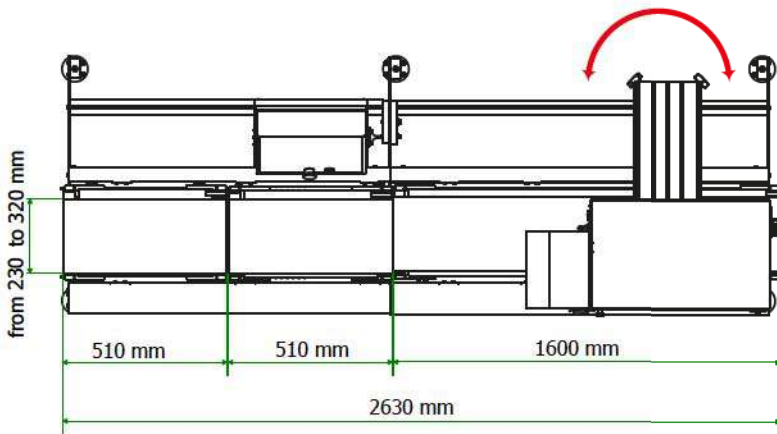
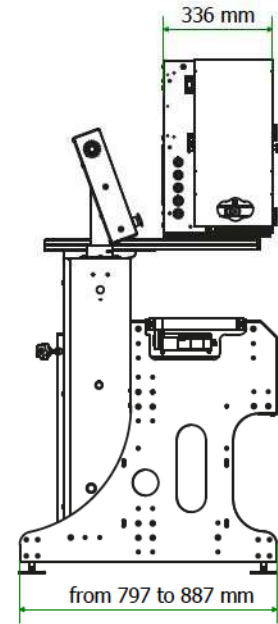
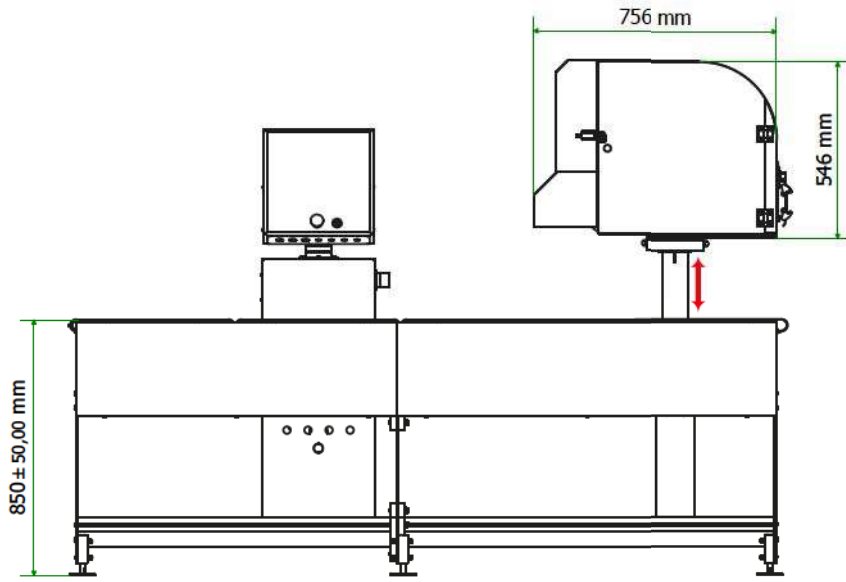

# Layout

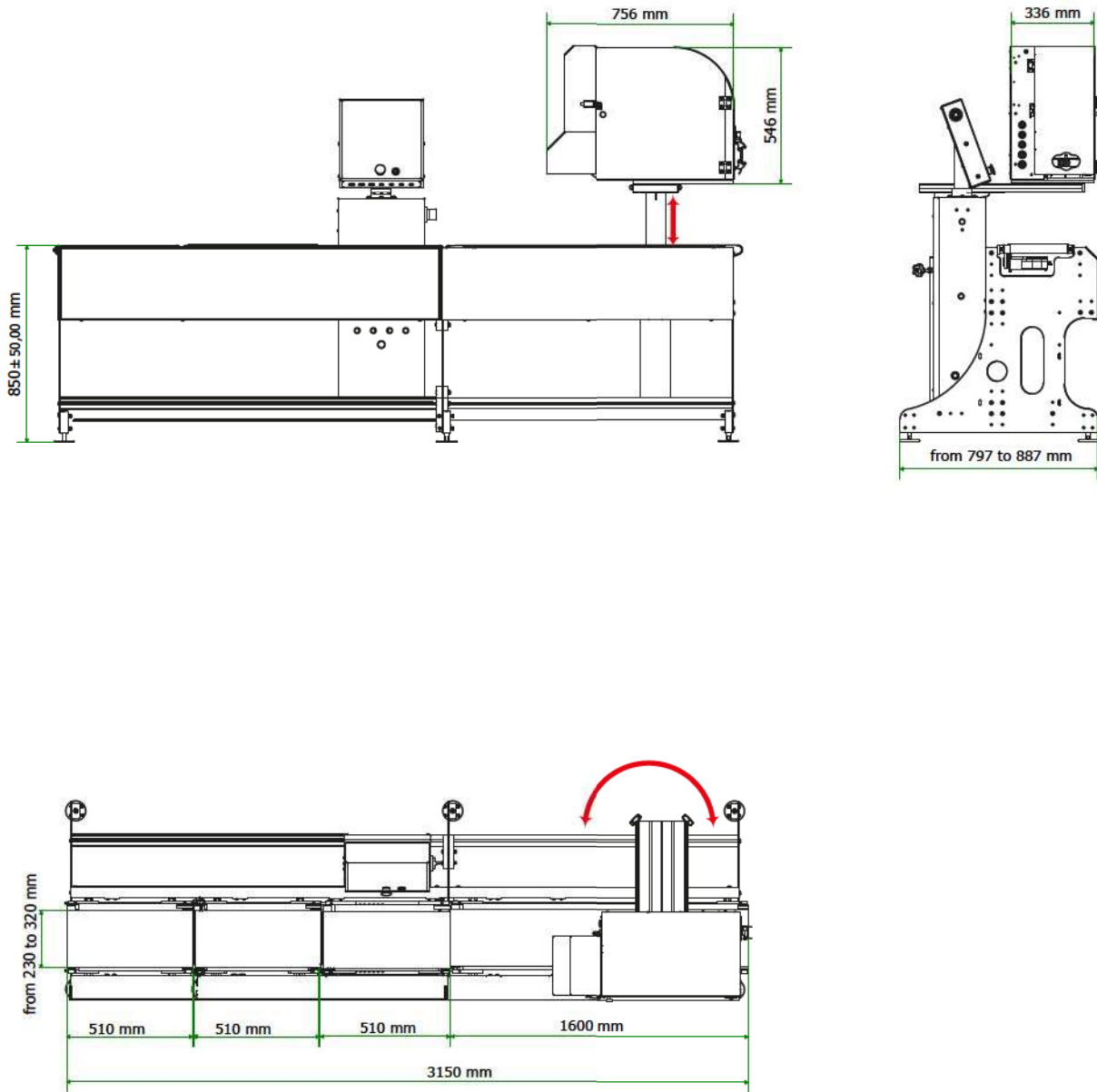

*Technical specifications and images may be subject to improvements and modifications without notice.*